

BOSCA[®]

Owner's Manual



SPIRIT 550 Wood Stove

Installation and Operating Instructions

Save These Instructions

Please read this entire manual before you install and use your BOSCA SPIRIT 550 Wood Stove.
Failure to follow instructions may result in property damage, bodily injury, or even death.

TABLE OF CONTENTS

<u>SAFETY NOTICES</u>	<u>2</u>
<u>INTRODUCTION</u>	<u>3</u>
<u>INSTALLATION</u>	<u>3</u>
<u>The floor</u>	<u>3</u>
<u>Installation clearances</u>	<u>5</u>
<u>Chimney Connection</u>	<u>6</u>
<u>CHIMNEY</u>	<u>6</u>
<u>Factory Built Chimney</u>	<u>7</u>
<u>Masonry Chimney</u>	<u>7</u>
<u>Masonry Fireplace</u>	<u>8</u>
<u>Chimney Height</u>	<u>8</u>
<u>Combustible Wall Chimney Connector Pass - Throughs</u>	<u>9</u>
<u>MOBILE HOME INSTALLATION</u>	<u>10</u>
<u>OPERATING AND LIGHTING INSTRUCTIONS</u>	<u>11</u>
<u>Lighting</u>	<u>11</u>
<u>Reloading</u>	<u>12</u>
<u>MAINTENANCE</u>	<u>12</u>
<u>Baffle</u>	<u>12</u>
<u>Disposal of Ashes</u>	<u>13</u>
<u>Glass Replacement</u>	<u>13</u>
<u>Glass Cleaning</u>	<u>13</u>
<u>Doors Gasket Replacement</u>	<u>14</u>
<u>Refractory Brick Replacement</u>	<u>14</u>
<u>Handle</u>	<u>15</u>
<u>Creosote - Formation and need for removal</u>	<u>15</u>
<u>TROUBLESHOOTING</u>	<u>16</u>
<u>REPLACEMENT PARTS</u>	<u>16</u>
<u>LIFETIME LIMITED WARRANTY</u>	<u>18</u>

SAFETY NOTICES

When your BOSCA SPIRIT 550 is not properly installed, a house fire may result. To reduce the risk of fire, follow the installation instructions. Contact local building, fire officials, or authority having jurisdiction about restrictions, permit and installation inspection requirements in your area.

DO NOT USE CHEMICALS OR FLUIDS TO START THE FIRE.

DO NOT BURN GARBAGE OR FLAMMABLE FLUIDS SUCH AS GASOLINE, NAPHTHA OR ENGINE OIL.

HOT WHILE IN OPERATION. KEEP CHILDREN, CLOTHING AND FURNITURE AWAY. CONTACT MAY CAUSE SKIN BURNS.

NEVER USE GASOLINE, GASOLINE-TYPE LANTERN FUEL, KEROSENE, CHARCOAL LIGHTER FLUID, OR SIMILAR LIQUIDS TO START OR "FRESHEN UP" A FIRE IN THIS STOVE, KEEP ALL SUCH LIQUIDS WELL AWAY FROM THE STOVE WHILE IT IS IN USE.

DO NOT ELEVATE FIRE, BUILD WOOD FIRE DIRECTLY ON FIREBOX HEARTH.

BURN NATURAL WOOD ONLY. DO NOT BURN ANY OTHER FUELS. PREFER HIGH-QUALITY WOOD, ADEQUATELY AIR-DRIED. AVOID BURNING GREEN WOOD.

KEEP WOOD A SAFE DISTANCE FROM THE STOVE AND KEEP IT OUT OF THE SPACE AROUND THE STOVE OR AREAS REQUIRED FOR REFUELING AND ASH REMOVAL.

THE BOSCA SPIRIT 550 IS APPROVED FOR MOBILE HOME INSTALLATION. PLEASE FOLLOW THIS MANUAL CAREFULLY FOR ANY INSTALLATION, INCLUDING IN A MOBILE HOME.

INTRODUCTION

We would like to congratulate you for selecting our BOSCA SPIRIT 550. By purchasing a BOSCA product, you receive the advantage of the strength, guarantee and the more than 20 years experience BOSCA has in producing stoves and heaters equipped with secondary air combustion system, which enable efficient consumption of the wood, as well as minimum impact to the general environment.

Bosca Chile S.A. is the leading company in the production of wood stoves in Chile, with more than 250,000 stoves sold and there are Bosca products installed in houses in Spain, Portugal, Argentina, Uruguay, Ecuador, and Mexico. In the production of our stoves, we use only the finest materials. This, along with the experience of the members of our staff, means for you a product of high quality and dependability.

The BOSCA SPIRIT 550 is a clean burning EPA certified, non-catalytic wood burning stove with 3,6 grams per hour particulate.

The BOSCA SPIRIT 550 has been tested and listed by OMNI-Test Laboratories, Inc. The test standards are UL1482 and ULC S627.

Please read this entire manual before you install and use your BOSCA SPIRIT 550. The purpose of this manual is to familiarize you with your SPIRIT 550's safe installation, operation and maintenance. It contains information that will be useful, so save it for future reference.

INSTALLATION

For your ultimate safety and the proper function of your stove, it should be installed in accordance with the instructions of this Manual.

The first step is to decide where is the most appropriate place to install your stove.

It is important to install the stove in an area with adequate air circulation and flow. This allows the warm air to more easily reach the intended rooms. Additionally, your stove's placement should enable, and not be an obstacle to, free movement of people, especially children.

Your stove and chimney connector must be far enough from combustible materials to meet all clearance requirements.

The floor

One of the main necessary precautions when installing a wood stove is to leave sufficient space between the stove (top, sides, back, front, and under stove pipes) and any other material that can catch fire.

If the stove is to be installed on a combustible floor, it must be placed on an approved 1/2" (13mm) non-combustible hearth pad with $k = 0.84 \text{ BTU/in ft}^2 \text{ hr } ^\circ\text{F}$. In the USA, the floor protector must extend 8" beyond each side of the flue loading door and 16" to the front. In Canada, the floor protector must extend 8" (200mm) beyond each side and the back of the appliance and 18" (450mm) to the front. (See fig. 1)

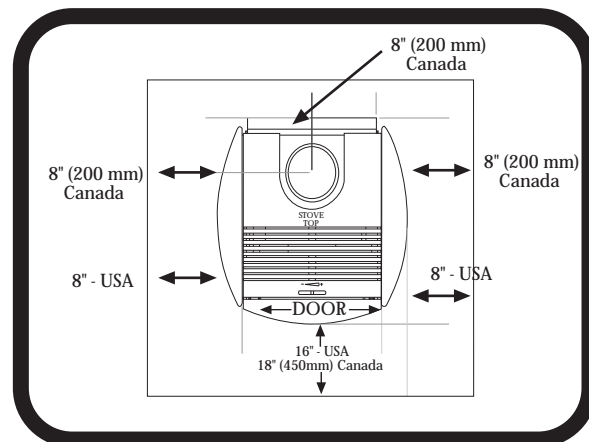

Fig. 1

In a rear vent installation the floor protection must also extend under the stovepipe a minimum of 2" (50mm) beyond either side of the pipe.

How to determine if alternate floor protection materials are acceptable.

All floor protection must be non-combustible (i.e., metals, brick, stone, mineral fiber boards, etc.). Any organic materials (i.e., plastics, wood paper products, etc.) are combustible and must not be used. The floor protection specified includes some form of thermal designation such as R-value (thermal resistance) or k-factor (thermal conductivity).

Procedure:

1. Convert specification to R-value:

i. R-value given - no conversion needed.

ii. k-factor is given with a required thickness (T) in inches: $R = \frac{1}{k} \times T$

iii. K-factor is given with a required thickness (T) in inches: $R = \frac{1}{K \times 12} \times T$

iv. r-factor is given with a required thickness (T) in inches: $R = r \times T$

2. Determine the R-value of the proposed alternate floor protector.

i. Use the formula in step (1) to convert values not expressed as "R".

ii. For multiple layers, add R-values of each layer to determine overall R-value.

3. If the overall R-value of the system is greater than the R-value of the specified floor protector, the alternate is acceptable.

Example: The specified floor protector should be 3/4-inch thick material with a k-factor of 0.84. The proposed alternate is 4" brick with an r-factor of 0.2 over 1/8" mineral board with a k-factor of 0.29.

Step (a): Use formula above to convert specification to R-value.

$$R = \frac{1}{k} \times T = \frac{1}{0.84} \times 0.75 = 0.893$$

Step (b): Calculate R of proposed system.

4" brick of $r = 0.2$, therefore:

$$R_{\text{brick}} = 0.2 \times 4 = 0.431$$

1/8" mineral board of $k = 0.29$, therefore

$$R_{\text{mineral board}} = \frac{1}{0.29} \times 0.125 = 0.431$$

$$R_{\text{total}} = R_{\text{brick}} + R_{\text{mineral board}} = 0.8 + 0.431 = 1.231$$

Step (c): Compare proposed system R_{total} of 1.231 to specified R of 0.893. Since proposed system R_{total} is greater than required, the system is acceptable.

Definitions

$$R = \frac{(\text{ft}^2) (\text{hr}) (^\circ\text{F})}{\text{Btu}}$$

$$k = \frac{(\text{Btu}) (\text{in})}{(\text{ft}^2) (\text{hr}) (^\circ\text{F})} = K \times 12$$

$$K = \frac{(\text{Btu}) (\text{ft})}{(\text{ft}^2) (\text{hr}) (^\circ\text{F})}$$

$$r = \frac{(\text{ft}^2) (\text{hr}) (^\circ\text{F})}{(\text{Btu}) (\text{in})} = \frac{1}{k}$$

Installation Clearances

It is extremely important that you respect required installation distances and that you respect local installation regulations. This is for your safety! The manufacturer is not responsible for the product, if it is not installed following these recommendations. These clearances may only be reduced by means approved by the regulatory authority.

A combustible surface is anything that can burn (i.e. sheet rock, wall paper, wood, fabrics etc.) These surfaces are not limited to those that are visible and also include materials that are behind non-combustible materials. If you are not sure of the combustible nature of a material, consult your local fire officials.

Parallel Installation

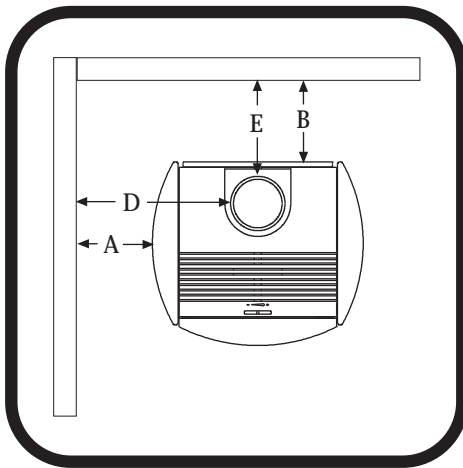

Corner Installation

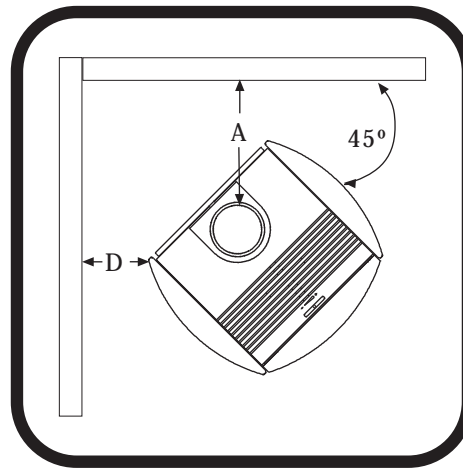

CLEARANCE REQUIREMENTS:	STANDARD RESIDENTIAL INSTALLATION (SINGLEWALL & DOUBLEWALL CONNECTOR):		ALCOVE INSTALLATION WITH (DOUBLE WALL CONNECTOR):
	Singlewall	Corner Doublewall	Doublewall
A.- SIDEWALL TO UNIT	13" (330 mm)	7" (178 mm)	7" (178 mm)
B.- BACKWALL TO UNIT	20" (508 mm)	15,5" (394 mm)	15,5" (394 mm)
C.- CORNERWALL TO UNIT	14" (356 mm)	11" (279 mm)	11" (279 mm)
D.- SIDEWALL TO CONNECTOR	22" (559 mm)	16" (406 mm)	16" (406 mm)
E.- BACKWALL TO CONNECTOR	22,5 (572 mm)	17" (432 mm)	17" (432 mm)
F.- CORNERWALL TO CONNECTOR	21" (533 mm)	18" (457 mm)	18" (457 mm)
G.- UNIT TO CEILING	49" (1.247 mm)	49" (1.247mm)	49" (1.247mm)
H.- FLOOR TO CEILING	84" (2.134 mm)	84" (2.134 mm)	84" (2.134 mm)

Note: Double wall is only allowed in US installations

Chimney Connection

The chimney connector is a single walled pipe used to connect the stove to the chimney. For use with the appliance the chimney connector MUST be 6" in diameter, with a minimum thickness of 24 gauge black steel or 26 gauge blued steel.

Aluminium and galvanized steel pipe is not acceptable for use with the appliance. These materials cannot withstand the extreme temperatures of a wood fire and can give off toxic fumes when heated.

Do not use the connector pipe as a chimney.

Each chimney connector or stovepipe section must be installed to the stove flue collar and to each other with the male (crimped) end toward the stove. See fig 2.

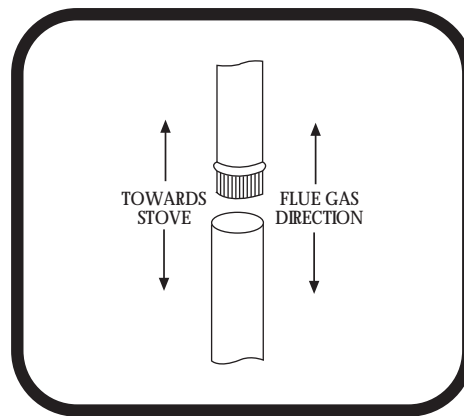

Fig. 2

This prevents any amount of condensed or liquid creosote from running down the outside of the pipe or the stovetop. All joints, including the flue collar connection must be secured with three sheet metal screws to ensure that the sections do not separate.

For the best performance the chimney connector should be as short and direct as possible, with no more than two 90° elbows. The maximum horizontal run is 36" and a recommended total length of stovepipe should not exceed 10 feet. Always slope horizontal runs upward ¼" per foot toward the chimney.

No part of the chimney connector may pass through an attic or roof space, closet or other concealed space, or through a floor ceiling. All sections of the chimney connectors must be accessible for cleaning. Where passage through a wall or partition of combustible construction is desired, the installation must conform with NFPA 211 or CAN/CSA-B365, and is also addressed in this manual.

CHIMNEY

DO NOT CONNECT THIS UNIT TO A CHIMNEY FLUE SERVING ANOTHER APPLIANCE. DO NOT CONNECT TO ANY AIR DISTRIBUTION DUCT OR SYSTEM.

This room heater must be connected to a 6" factory built UL 103 HT chimney (ULC S629, in Canada) or a code-approved masonry chimney with a flue liner.

Factory Built Chimney

When a metal prefabricated chimney is used, BOSCA's installation instructions must be followed. You must also purchase (from an authorized retailer) and install the ceiling support package or wall pass-through and "T" section package, firestops (where needed), insulation shield, roof flashing, chimney cap, etc. Maintain proper clearance to the structure as recommended by BOSCA. The chimney must be the required height above the roof or other obstructions for safety and proper draft operation. (See fig. 3)

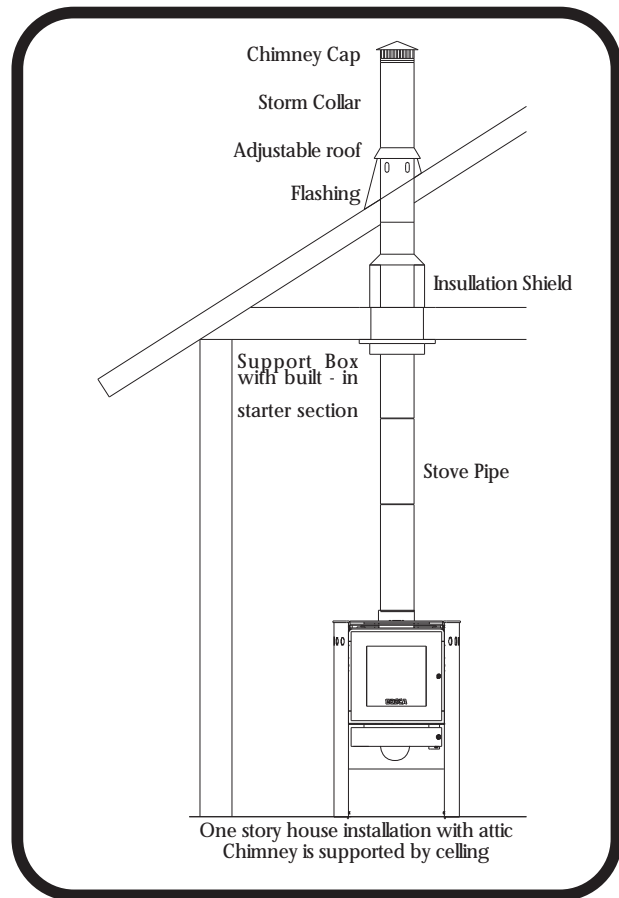

Fig. 3

Masonry Chimney

Ensure that a masonry chimney meets the minimum standards of the National Fire Protection Association (NFPA) by having it inspected by a professional. Make sure there are no cracks, loose mortar or other signs of deterioration and blockage. Have the chimney cleaned before the stove is installed and operated. When connecting the stove through a combustible wall to a masonry chimney, special methods are needed (See fig. 4). Refer to Combustible Wall Chimney Connector Pass-Throughs on page 9.

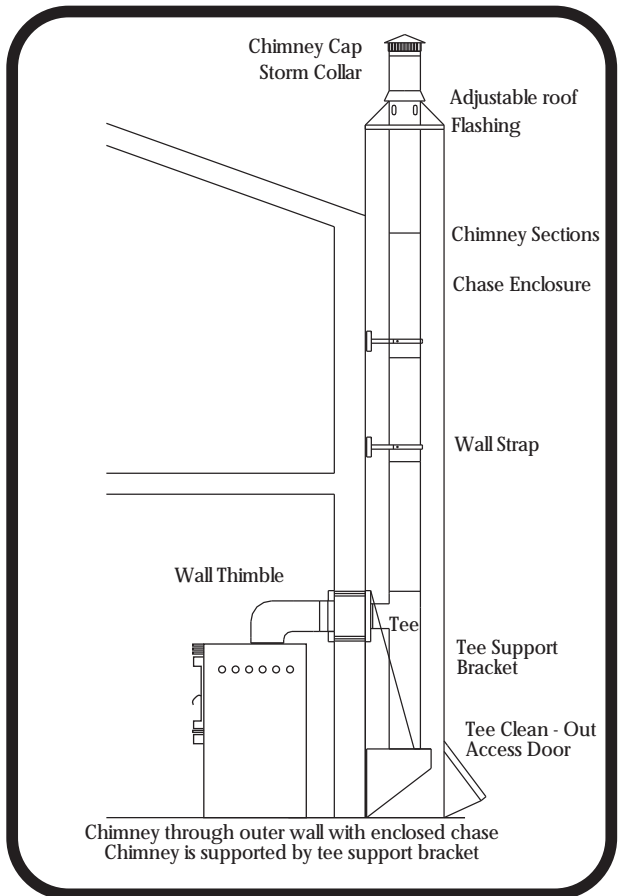

Fig. 4

Masonry Fireplace

There are listed kits available to connect a stove to a masonry fireplace. The kit is an adapter that is installed at the location of the fireplace damper. The existing damper may have to be removed to allow installation. (See fig. 5)

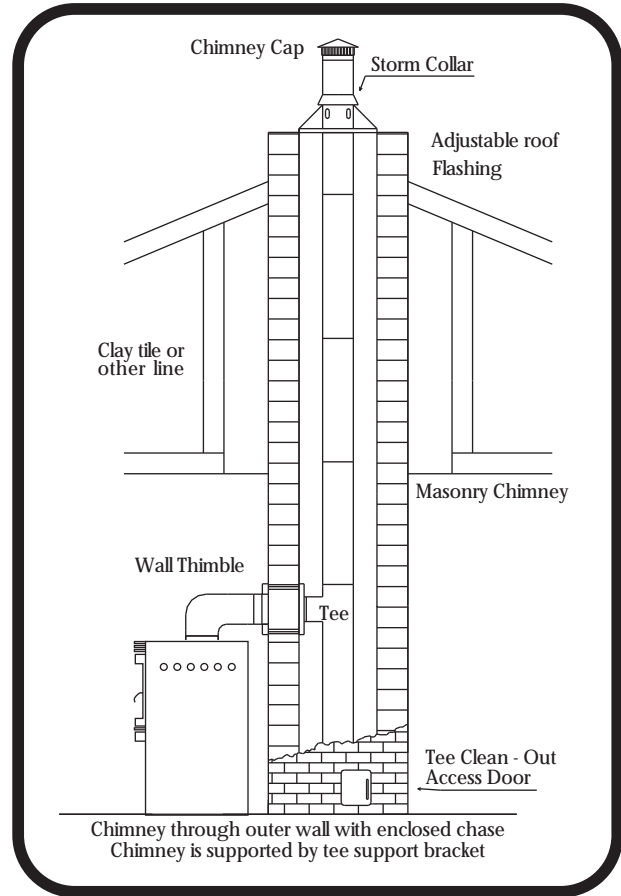

Fig. 5

Chimney Height

A masonry chimney or a listed factory-built chimney must be the required height above the roof and any other nearby obstructions. The chimney must be at least 3' (90 cm) higher than the highest point where it passes through the roof and at least 2' (60 cm) higher than the highest part of the roof or structure that is within 10' (305 cm) of the chimney, measured horizontally (See fig. 6).

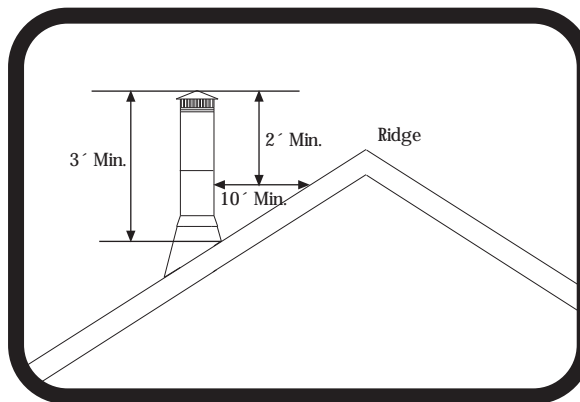
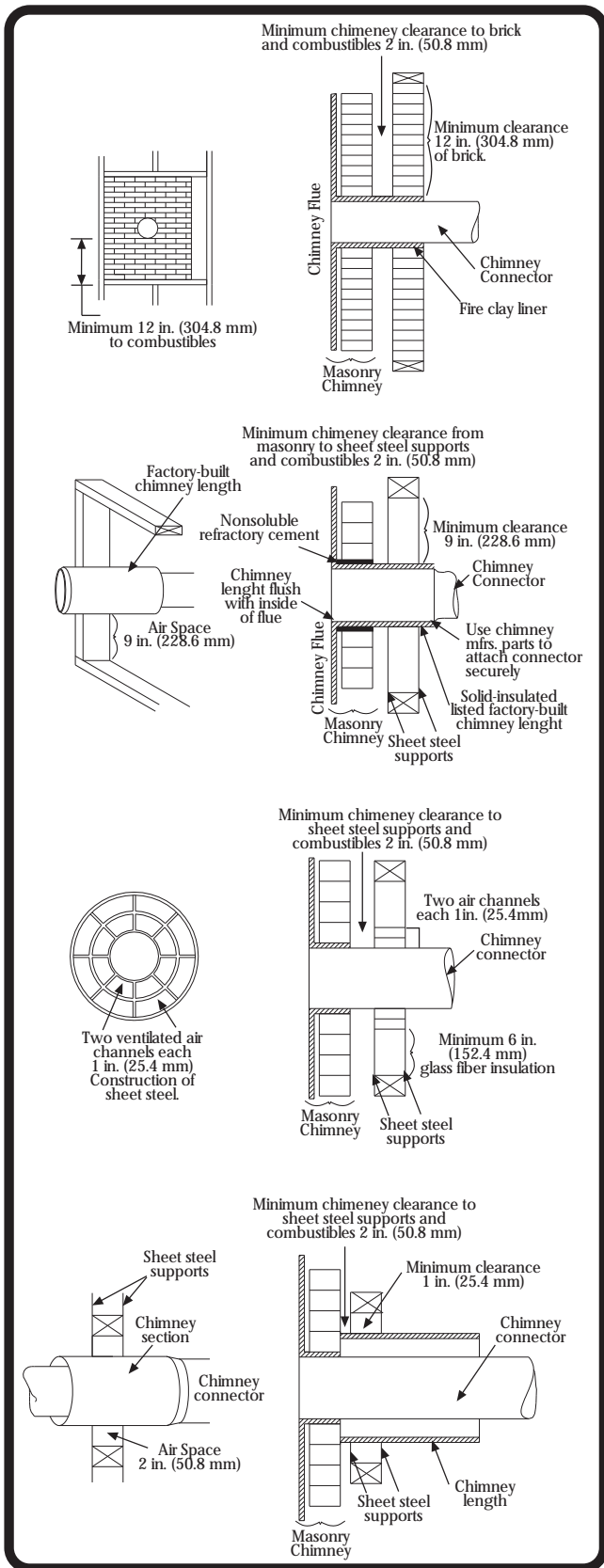

Fig. 6

Combustible Wall Chimney Connector Pass - Throughs



Method A. 12" (304.8 mm) Clearance to Combustible Wall Member: Using a minimum thickness 3.5" (89 mm) brick and a 5/8" (15.9 mm) minimum wall thickness clay liner, construct a wall pass-through. The clay liner must conform to ASTM C315 (Standard Specification for Clay Fire Linings) or its equivalent. Keep a minimum of 12" (304.8 mm) of brick masonry between the clay liner and wall combustibles. The clay liner shall run from the brick masonry outer surface to the inner surface of the chimney flue liner but not past the inner surface. Firmly grout or cement the clay liner in place to the chimney flue liner.

Method B. 9" (228.6 mm) Clearance to Combustible Wall Member: Using a 6" (152.4 mm) inside diameter, listed, factory-built Solid-Pak chimney section with insulation of 1" (25.4 mm) or more, build a wall pass-through with a minimum 9" (228.6 mm) air space between the outer wall of the chimney length and wall combustibles. Use sheet metal supports fastened securely to wall surfaces on all sides, to maintain the 9" (228.6 mm) air space. When fastening supports to chimney length, do not penetrate the chimney liner (the inside wall of the Solid-Pak chimney). The inner end of the Solid-Pak chimney section shall be flush with the inside of the masonry chimney flue, and sealed with a non-water soluble refractory cement. Use this cement to also seal to the brick masonry penetration.

Method C. 6" (152.4 mm) Clearance to Combustible Wall Member: Starting with a minimum 24 gage (.024" [61 mm]) 6" (152.4 mm) metal chimney connector, and a minimum 24 gage ventilated wall thimble which has two air channels of 1" (25.4 mm) each, construct a wall pass-through. There shall be a minimum 6" (152.4 mm) separation area containing fiberglass insulation, from the outer surface of the wall thimble to wall combustibles. Support the wall thimble, and cover its opening with a 24-gage minimum sheet metal support. Maintain the 6" (152.4 mm) space. There should also be a support sized to fit and hold the metal chimney connector. See that the supports are fastened securely to wall surfaces on all sides. Make sure fasteners used to secure the metal chimney connector do not penetrate chimney flue liner.

Method D. 2" (50.8 mm) Clearance to Combustible Wall Member: Start with a solid-pak listed factory built chimney section at least 12" (304 mm) long, with insulation of 1" (25.4 mm) or more, and an inside diameter of 8" (2 inches [51 mm]) larger than the 6" [152.4 mm] chimney connector. Use this as a pass-through for a minimum 24-gage single wall steel chimney connector. Keep solid-pak section concentric with and spaced 1" (25.4 mm) off the chimney connector by way of sheet metal support plates at both ends of chimney section. Cover opening with and support chimney section on both sides with 24 gage minimum sheet metal supports. See that the supports are fastened securely to wall surfaces on all sides. Make sure fasteners used to secure chimney flue liner.

- NOTES:**
1. Connectors to a masonry chimney, excepting method B, shall extend in one continuous section through the wall pass-through system and the chimney wall, to but not past the inner flue liner face.
 2. A chimney connector shall not pass through an attic or roof space, closet or similar concealed space, or a floor, or ceiling.

MOBILE HOME INSTALLATION

For use only in USA (not allowed in Canada).

Follow these special requirements for installing your stove in a mobile home:

- An outside air inlet must be provided for combustion and must remain clear of leaves, debris ice and/or snow. It must be unrestricted while unit is in use to prevent room air starvation which can cause smoke spillage and an inability to maintain a fire. Smoke spillage can also set off smoke alarms.

- Outside air inlet installation: Use a BOSCA connector (see Replacement Parts, pg. 16) which you can purchase from an official BOSCA dealer, a 4" single wall aluminum flex pipe of appropriate length for installation, a rain cap and two 4" clamps, available at your local hardware retailer.

To install the outside air inlet, place the connector over through the hole behind the heater, connect the flex pipe and attach it securely with one of the two clamps. The other side of the flex pipe should be connected on the outside to the rain cap.

- Permanently attach the stove to your mobile home's floor. The pedestal must be bolted to the floor. Use 1/4" holes in the base to bolt down the stove.

- Regulation requires that unit must be grounded. Attach a piece of # 8 cooper wire, at least 18" in length from the stove to the chassis of the mobile home.

- Stove must be installed with an approved UL103 HT ventilated chimney connector, UL103 HT chimney and terminal cap with spark arrestor. Never use a single wall connector in a mobile home installation.

- See clearances to combustibles on page 5 of this Manual or in the Serial Number Label on the back of the stove.

- Follow the floor protections requirements detailed on page 3.

- In Canada, this stove must be connected to a 6" factory-built chimney conforming to CAN/ULC-629M.

- Use silicone to create an effective vapor barrier at the location where the chimney or other components penetrates to the exterior of the structure.

- Follow the chimney and chimney connector manufacturer's instructions when installing the flue system for use in mobile homes.

- Burn wood only. Other fuels may generate poisonous gases.

- Chimney must be removed when transporting mobile home.

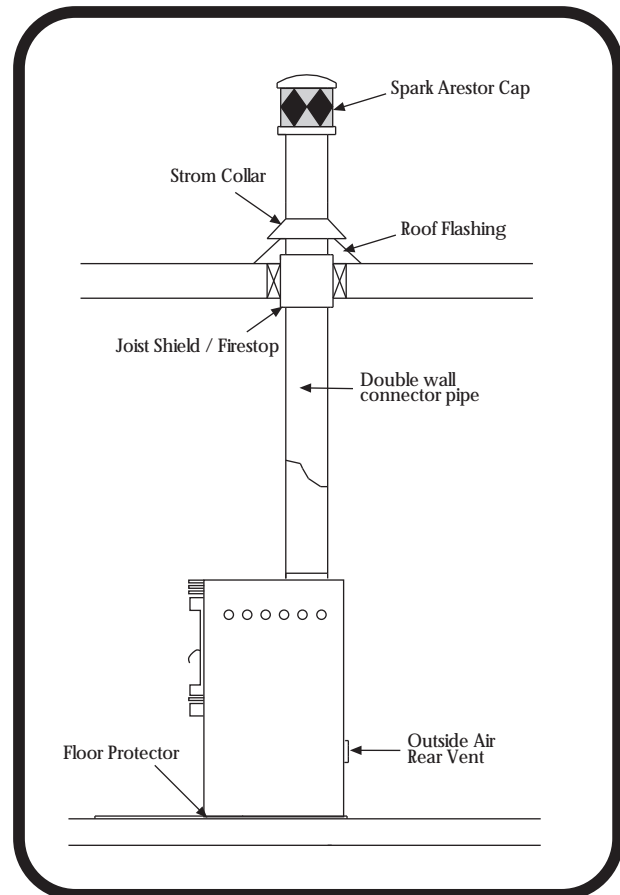

WARNING:
DO NOT INSTALL IN SLEEPING ROOM

CAUTION:
THE STRUCTURAL INTEGRITY OF THE MOBILE HOME FLOOR, WALL AND CEILING/ROOF MUST BE MAINTAINED.

OPERATING AND LIGHTING INSTRUCTIONS

Your SPIRIT 550's performance depends largely on how it is operated. Please read this section carefully before lighting your first fire.

When you light your first fire, the stove will emit some smoke and the smell of paint. This is normal. Open the windows to vent the room and eliminate the smell.

Before lighting your stove, ensure that the baffle is correctly installed. For baffle installation instructions, see page 12 (Maintenance).

Before lighting your stove, ensure that the refractory bricks are correctly installed. For refractory bricks installation instructions, see page 14 (Maintenance).

Lighting

- Place crushed sheets of paper or firelighters in the center of the firebox.
- Place some kindling on top of the paper and some small split logs, preferably in a vertical position.
- Light the fire and close the door.
- Open the door of the ashtray and leave it this way for approximately 3 minutes or until the split logs are alight.
- Add the load of firewood, placing the lightest logs directly over the fire and the heavier ones on top of these.
- Close the door of the firebox and maintain the door of the ashtray open for approximately 5 more minutes.
- Once the logs are alight, close the door and place the Air Control on HIGH for 20 minutes.
- When the stove reaches the operation temperature and there is sufficient draft, graduate the Air Control to the desired position. It is recommendable to slowly adjust this command before graduating to the MEDIUM position (prolonged combustion).

You will find by experience how to best manage your stove to your liking. You must not expect an immediate reaction from the fire when moving the Air Control. The flame will not intensify nor extinguish quickly as it would with liquid or gas fuels. Solid fuels, like firewood, react slowly.

If the fire is initiated as instructed, a good base is established for an effective combustion that is smokeless and that does not pollute.

WARNING
DO NOT OVERFIRE. IF THE STOVETOP OR
CHIMNEY CONNECTOR PIPE GLOW RED,
YOU ARE OVERFIRING.

IMPORTANT
DO NOT OPERATE THE STOVE FOR
PROLONGED PERIODS WITH THE DOOR OF
THE ASHTRAY OPEN. DO SO ONLY UNTIL THE
WOOD LOAD IS ALIGHT.

To obtain good combustion during the whole night, proceed as follows:

- Form a base of live coals at the bottom of the firebox.
- Load the stove completely with dry firewood.
- When flames begin to appear on the logs move the Air Control to MEDIUM.

How do I load my stove after a prolonged combustion?

- At the end of a long combustion cycle, reestablish the fire adding a few small split logs and small logs.
- Open the door of the ashtray for 5 minutes or until the split logs and small logs are alight.
- Allow the temperature of the stove to recuperate before adding larger logs.
- Reload the stove according to the description above.

MAINTENANCE

The SPIRIT 550 requires little maintenance. However, there are parts of your stove that should be checked periodically.

Baffle

Your SPIRIT 550 stove has a removeable baffle that needs to be replaced periodically, depending on the stove's use. When the baffle needs to be removed, make sure that the stove is cold before putting your hands into the firebox.

To replace the baffle, you have to dismantle the rear panel of your stove (fig.7):

- 1) Release the 4 bolts located on the sides of the rear panel, using a 10mm wrench.
- 2) Remove the rear panel, pulling it towards you.
- 3) Release the bolts that fix the baffle to the firebox, using a 10mm wrench.
- 4) Once the bolts are loose, slide the baffle down as indicated in figure 8. Carefully, angle the baffle on one side to make sure it doesn't accidentally fall, as this may result in serious injury (fig. 9)
- 5) To place the new baffle in its proper position, insert it into the firebox, in such a way that it rests on the support brackets installed specially for the baffle. Make sure that the baffle air pipe is inserted completely into the hole in the back of the firebox (Fig 10) and the bolts have gone through the holes to the outside of the firebox.
- 6) Bolt the baffle to the rear wall of the firebox from the outside.
- 7) Place the rear panel back in place, be sure that it is correctly set and bolt it.

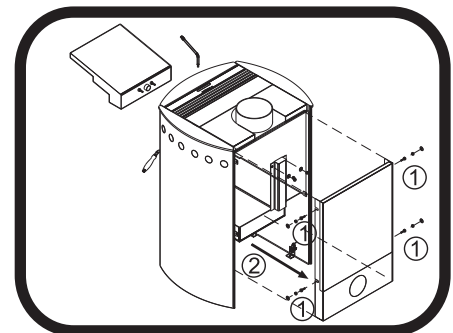

Fig. 7

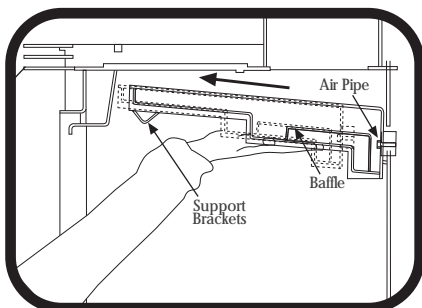

Fig. 8

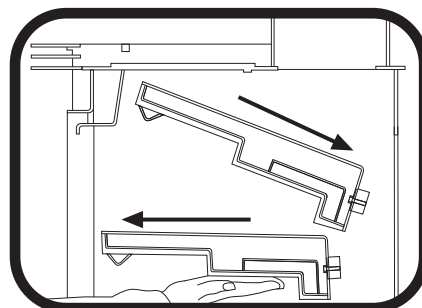

Fig. 9

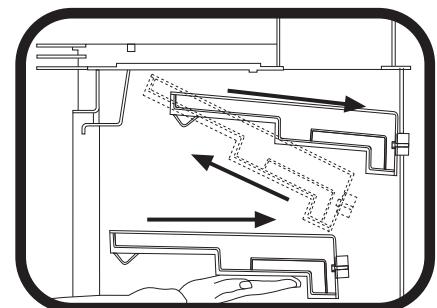

Fig. 10

Disposal of Ashes

Your unit's firebox has a grooved base, through which the ashes from the wood burned automatically deposit into the ashbin. When the ashbin is full, make sure that the stove and the ashes are cold (remember that the coals can remain hot for up to 36 hours) and place the ashes in a metal container with a tight fitting lid. The closed container of ashes should be placed on a noncombustible floor or on the ground, well away from all combustible materials, pending final disposal. If the ashes are disposed of by burial in soil or otherwise locally dispersed they should be retained in the closed container until all cinders have thoroughly cooled.

Note: To open the ashbin door, you have to use the steel handle provided with your stove.

Glass Replacements

The front glass is a ceramic glass, especially made for use in wood stoves, and should therefore not be marred by normal use of the stove.

If for any reason the glass does break, it will be necessary to replace it. Never operate your stove with broken glass.

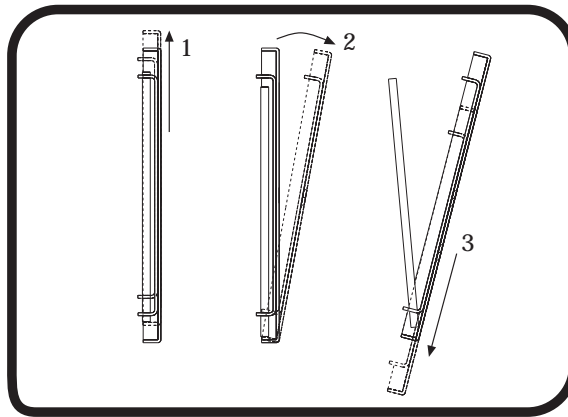

Fig. 11

Replace the glass as follows:

- Make sure that the fire is completely extinguished and the stove is cold.
- Protect your hands with gloves that are appropriate for this type of work.
- Remove the front door, carefully pushing it upward (fig 11).
- Place the door on a flat surface.
- Unscrew the bolts that hold down the stainless-steel frame on the stove door.
- Separate the door frame from the glass. The glass should be loose on the door, once the frame has been removed.
- Place a new sheet of glass on the door, reset the frame in its original position, then screw the frame in place on the door.
- Reinstall the door, inserting the bottom part first, then the top part.
- Before lighting a new fire, ensure that the door is seated in its correct position.

Use only ceramic glass for use in wood stoves. Do not use other type of glass.

If the ceramic glass of your stove needs to be replaced, contact your Official BOSCA Dealer.

Glass Cleaning

One of the more attractive features of your stove is that you can actually enjoy seeing the fire. However, your view may be obscured when the glass becomes dirty.

In order to minimize this, we recommend the following advice:

- The main cause of dirt spots on your glass is directly connected with the humidity content of the wood used, along with maintaining the Air Control setting on "Low" Position. Use only dry wood. Store it adequately, and keep the Air Control at the "Medium" position.
- Clean the glass periodically with a commercial stove glass cleaner, waiting until the glass is completely cold before cleaning.

Doors Gasket Replacement

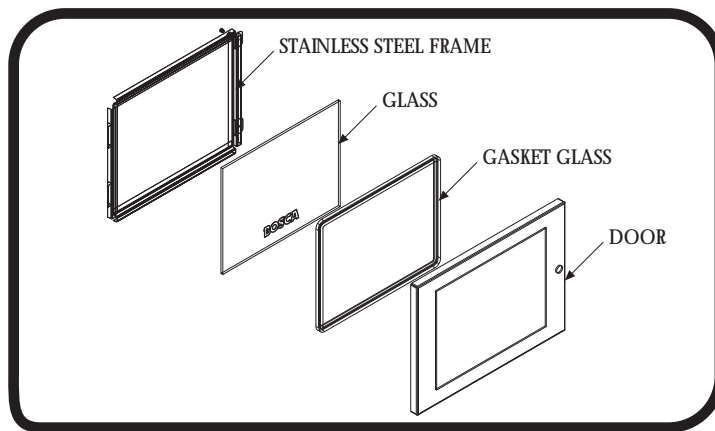

Your SPIRIT 550 uses rope-type fiberglass gaskets at the interior of the front and ashtray doors to sealed it. After a time of use, gaskets can become brittle and compressed, begin to lose their effectiveness and need to be replace.

To replace any gasket, be sure that the fire is out and the stove is cold and follow as is describe:

- Use Fil-Tec™ MD .500 G Black Fiberglass Rope or equivalent.
- Remove the existing gasket.
- Clean the stainless steel channel.
- Measure the length of the rope by laying it out in the stainless steel channel.
- Remove the rope from the channel and cut it to the appropriate length. Take care to ensure that the rope does not unravel.
- Place a bead of high-temperature adhesive in the clean stainless-steel channel.
- Beginning at one of the ends, press the gasket into the stainless-steel channel interior.
- Before cutting, make sure the rope ends properly meet. Do not overlap rope ends.
- Firmly press the rope en make sure it properly seats into the stainless-steel channel interior.
- Clean any excess adhesive and allow to dry.

Refractory Bricks Installing and Replacement

Your SPIRIT 550's firebox interior is covered with 18 refractory bricks (figure 13 a). To avoid damages in your stove during the transport , the refractory bricks are not installed and are stored in a box inside your stove firebox.

To install the refractory bricks, proceed as follow:

- Use gloves to protect your hands
- Install the refractory bricks as shown in figure 13 b.

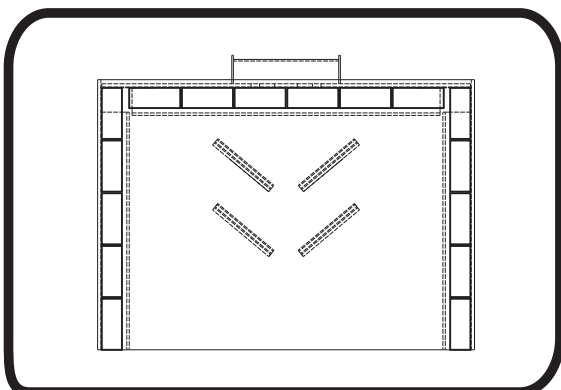

fig.13 a.

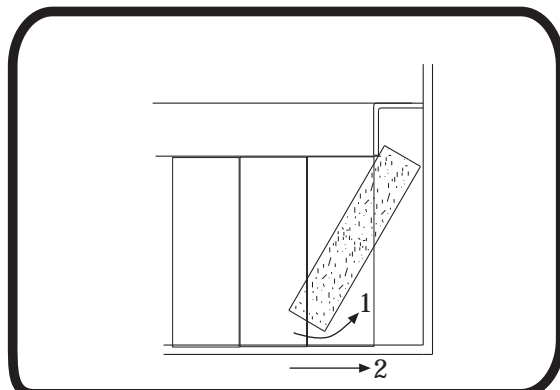

fig. 13 b.

Some bricks may break due to the normal use of the appliance or from impact when loading wood. If this occurs, proceed as follows, after making sure that any fire is extinguished and the appliance and brick are cold:

- Use gloves to protect your hands
- Clean any ashes from the firebox
- Take hold of the brick to be replaced, and push it upwards. This should leave you enough space to move the bottom of the brick toward the center of the firebox
- Clean any pieces of brick remaining in the space where the new brick will be placed
- To insert the new brick, place the upper end in the molding in the top part of the firebox
- Once the upper part of the brick is well seated, push it towards the inside surface of the firebox, until the brick is completely seated in place.

If you need to replace Refractory Bricks, check with your Official BOSCA Dealer.

Handle

After some use, it may be necessary to replace the wood part of the front door handle.

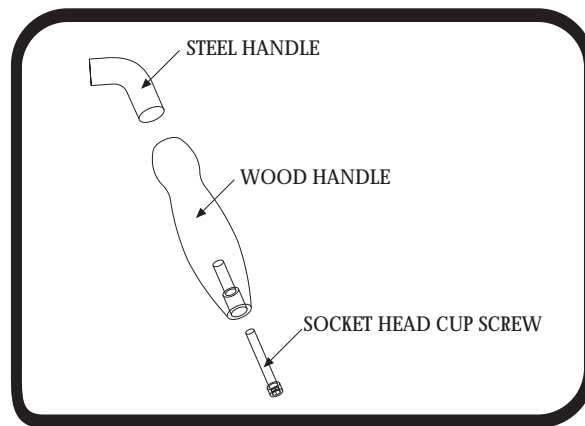

Replace the wooden handle as follows:

- Be sure that the fire is out and the stove is cold
- Remove the existing wood handle (use a N°4 Allan key)
- Turn the screw as far as possible and remove

To replace the wood handle, check with your Official BOSCA Dealer.

Creosote - Formation and need for removal

When wood is burned slowly, it produces tar and other organic vapors, which combine with expelled moisture to form creosote. The creosote vapors condense in the relatively cool chimney flue of a slow burning fire. As a result, creosote residue accumulates on the flue lining. When ignited this creosote makes an extremely hot fire.

The chimney connector and chimney should be inspected at least every two months during the heating season to determine if creosote build up has occurred.

If creosote has accumulated it should be removed to reduce the risk of a chimney fire.

TROUBLE SHOOTING

Your SPIRIT 550 will operate with few problems, and most of those will occur due to incorrect operation, poor-quality wood, improper installation, or failure to clean the flue piping.

The following lists solutions to the most common problems in the operation of the SPIRIT 550:

Problem	Solution
Insufficient Heat	-Use seasoned wood -Reload your stove when it has a good bed of embers - Set the Air Control in "Médium" or "High" position.
Stove smokes	-Use seasoned wood - It is normal for your stove to emit smoke during the first few minutes of operation. The smoke will dissipate when the firebox reaches the normal operating temperature..
Sooted Glass	- Use seasoned wood - Keep the Air Control at "Medium" or "High" position - Make sure that the gasket is in good condition.
Melted Baffle	- If your heater is more than 2 years old, replace the baffle.-

REPLACEMENT PARTS

N°	Code	Description
1	12720064	Door (without ceramic glass)
2	12720078	Ceramic Glass (with gasket)
3	10310274	Refractory Bricks (set)
4	10320127	Ashpan
5	12720069	Ashpan Door (with rope)
6	12720070	Wood Handle Assembly
7	12720071	Baffle
8	10310320	Outside Air Connector
9	10310209	Glass Retainer (with brackets, screws and rope)
10	12720073	Damper Handle
11	12720072	Owner's Manual

REPLACEMENT PARTS

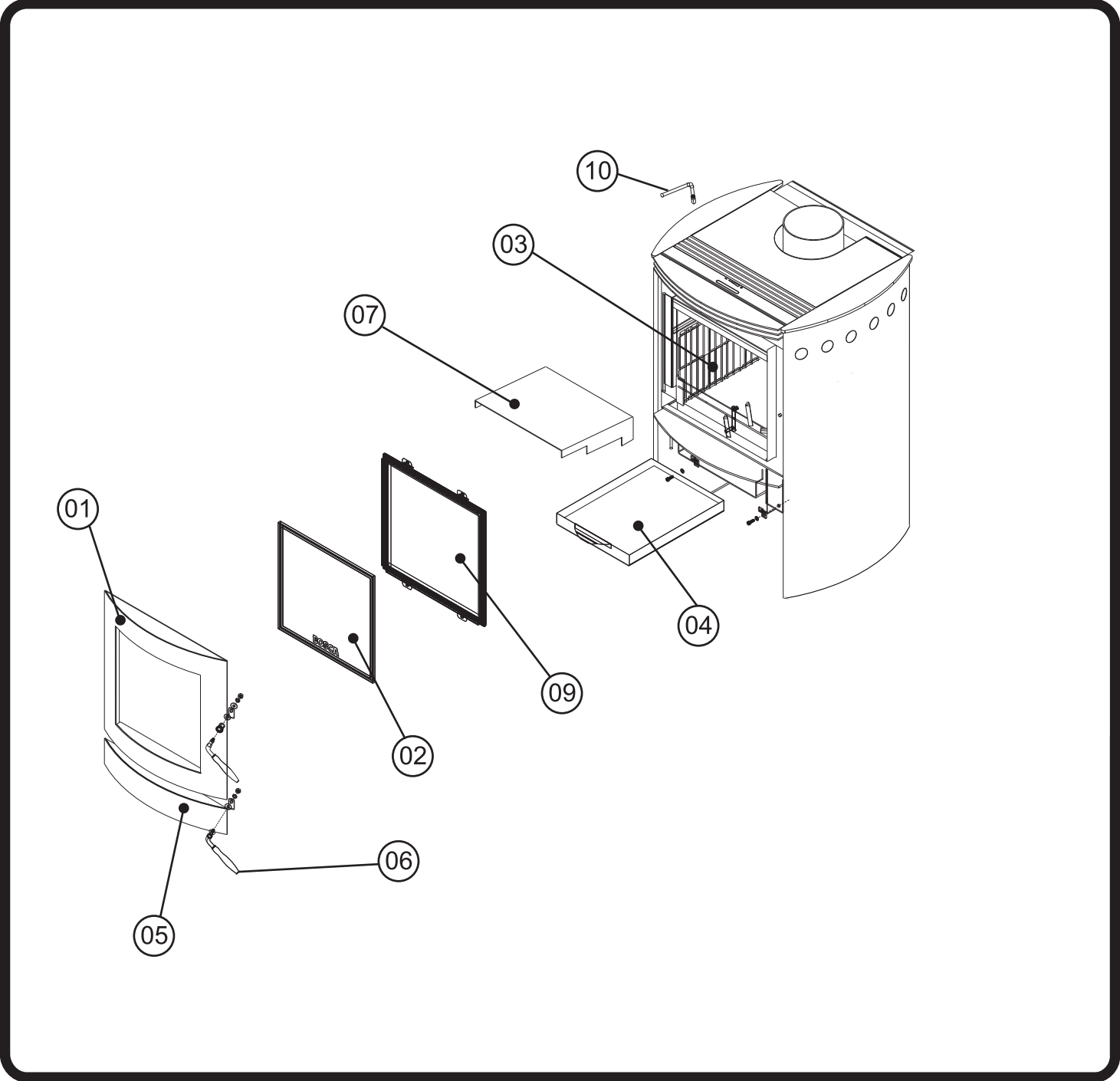



DO NOT REMOVE THIS LABEL / NE PAS ENLEVER CETTE ETIQUETTE
 CONTACT LOCAL BUILDING OR FIRE OFFICIALS ABOUT INSTALLATION AND RESTRICTIONS IN YOUR AREA. / REINSEIGNEZ-VOUS AUPRES DES AUTORITES LOCALES DE LA CONSTRUCTION ET DE LA PREVENTION DES INCENDIES AU SUJET DES RESTRICTIONS ET INSPECTIONS D'INSTALLATION DANS VOTRE REGION.



LISTED SOLID FUEL BURNING APPLIANCE SUITABLE FOR USE IN RESIDENTIAL INSTALLATIONS. / APPAREIL DE CHAUFFAGE A COMBUSTIBLES SOLIDES HOMOLOGUE POUR INSTALLATIONS RESIDENTIELLES.

MODEL / MODÈLE: **SPIRIT 550**

TESTED TO / TESTE AUX NORMES: UL 1482, ULC-S627
 Room Heater, Solid Fuel Type. For use in mobile homes only in US.
 Appareil de Chauffage à Combustibles Solides. Pour usage dans les maisons mobiles seulement dans EU.

Serial Number / Numero de Serie

PREVENT HOUSE FIRES - Install and use only in accordance with the manufacturer's installation and operating instructions. Contact your local building or fire officials about restrictions and installation inspection in your area. Refer to local building codes and manufacturer's instructions for precautions required for passing a chimney through a combustible wall ceiling. Do not run a chimney connector through a combustible wall ceiling. Do not connect this unit to a chimney flue serving another appliance. Clearances may be reduced by methods specified in NFPA 211, listed wall shields, pipe shields, or other means approved by local building or fire officials.

PREVENTION DES INCENDIES: Installez et utilisez conformément aux instructions du fabricant. Renseignez-vous auprès des autorités locales de la construction et de la prévention des incendies au sujet de restrictions et inspections d'installation dans votre région. Des méthodes spéciales sont requises lors du percage d'un mur ou plafond. Vérifier les instructions du fabricant et les codes du bâtiment. Ne pas faire passer le tuyau de cheminée directement à travers une surface combustible. Ne pas connecter cet appareil à la cheminée d'un autre appareil. Les dégagements minimaux des matériaux combustibles peuvent être réduits selon les méthodes spécifiées dans NFPA 211, avec des protections murales homologuées, des protections de cheminée homologuées, ou d'autres moyens approuvés par les autorités de la construction et de la prévention des incendies.

For use with solid wood fuel only (cord wood).

Pour usage uniquement avec du bois.

Operated with feed door closed - open to feed fire only.

Faites fonctionner l'appareil avec les portes de chargement fermées - ouvrir uniquement pour charger.

Do not use a grate to elevate fire - build fire directly on hearth.

Ne pas utiliser une grille supplémentaire pour élever le feu - faites le feu directement sur le foyer.

Do not operate with the ash door open.

Ne pas faire fonctionner l'appareil avec la porte cendrier ouverte.

DO NOT OVERFIRE - If heater or chimney connectors glows, you are overfiring.

NE PAS SURCHAUFFER - Si une partie de l'appareil ou du raccordement de cheminée commence à rougeoier, vous êtes en situation de surchauffe.

Inspect and clean chimney frequently - under certain conditions of use, creosote buildup may occur rapidly.

Inspecter et nettoyer la cheminée fréquemment; dans certaines conditions de fonctionnement (par exemple, mise au ralenti sans attendre la combustions des volatiles) une formation de créosote goudron peut se produire rapidement.

FREESTANDING / INSTALLATION

STANDARD RESIDENTIAL FREESTANDING / INSTALLATIONS REQUIRE: 6" diameter, minimum 24 MSG black or 26 MSG blued steel connector, with listed (type UL103 HT) factory-built chimney, suitable for use with solid fuels or masonry chimney. / pour les installations résidentielles: Utiliser un connecteur de cheminée de 6" de diamètre, en acier noir de minimum 24 MSG ou en acier bleu de minimum 26 MSG vers une cheminée préfabriquée homologuée (type UL103 HT ou ULC S629) ou vers une cheminée maçonnée.

CLEARANCE REQUIREMENTS: DÉGAGEMENTS MINIMAUX DES MATÉRIEAUX COMBUSTIBLES:	STANDARD RESIDENTIAL INSTALLATION (SINGLEWALL & DOUBLEWALL CONNECTOR): INSTALLATION RÉSIDENTIELLE STANDARD (TUYAU DE RACCORDEMENT À SIMPLE PAROÏET À DOUBLE PAROÏ):		ALCOVE INSTALLATION WITH (DOUBLE WALL CONNECTOR): INSTALLATION DANS UN ALCOVE (TUYAU DE RACCORDEMENT AU DOUBLE PAROÏ)
	Singlewall	Corner Doublewall	Doublewall
A- SIDEWALL TO UNIT / DU MUR DE CÔTÉ AU POÈLE	13" (330 mm)	7" (178 mm)	7" (178 mm)
B- BACKWALL TO UNIT / DU MUR ARRIÈRE AU POÈLE	20" (508 mm)	15,5" (394 mm)	15,5" (394 mm)
C- CORNERWALL TO UNIT / DU MUR DU COIN AU POÈLE	14" (356 mm)	11" (279 mm)	11" (279 mm)
D- SIDEWALL TO CONNECTOR / DU MUR DE CÔTÉ AU RECCORD DE CHEMINÉE	22" (559 mm)	16" (406 mm)	16" (406 mm)
E- BACKWALL TO CONNECTOR / DU MUR ARRIÈRE AU RECCORD DE CHEMINÉE	22,5" (572 mm)	17" (432 mm)	17" (432 mm)
F- CORNERWALL TO CONNECTOR / DU MUR DE COIN AU RECCORD DE CHEMINÉE	21" (533 mm)	18" (457 mm)	18" (457 mm)
G- UNIT TO CEILING / DU POÈLE AU PLAFOND	49" (1.247 mm)	49" (1.247mm)	49" (1.247mm)
H- FLOOR TO CEILING / DU SOL AU PLAFOND	84" (2.134 mm)	84" (2.134 mm)	84" (2.134 mm)

For additional types of installations and clearances consult your owners manual.

Pour d'autres modes d'installation et dégagements supplémentaires consultez votre manuel du propriétaire.

Note: Double wall is only allowed in US installations

MINIMUM CLEARANCES TO COMBUSTIBLES:
DÉGAGEMENTS MINIMAUX AUX MATÉRIEAUX COMBUSTIBLES:

NON - COMBUSTIBLE FLOOR PROTECTOR
PROTECTEUR DE PLANCHER INCOMBUSTIBLE

ALCOVE INSTALLATION / INSTALLATION ALCOVE

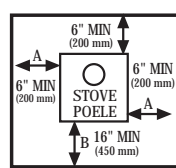
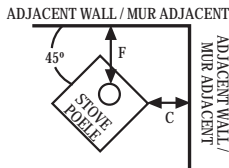
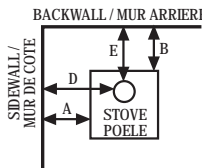

FLOOR PROTECTOR MUST BE A 1/2" MINIMUM THICKNESS, NON-COMBUSTIBLE MATERIAL HAVING AN EQUAL OR BETTER INSULATING VALUE (LOWER K VALUE) OF KX.84. IT MUST EXTEND BENEATH HEATER, AND TO THE FRONT/SIDES/REAR AS INDICATED.

LE PROTECTEUR DE PLANCHER DOIT ÊTRE D'UNE ÉPAISSEUR MINIMUM DE 1/2", D'UN MATÉRIEL INCOMBUSTIBLE AVANT UNE VALEUR D'ISOLATION DE KX.84. IL DOIT S'ÉTENDRE EN DESSOUS DE L'APPAREIL ET AU DEVAANT, AUX CÔTÉS ET À L'ARRIÈRE DE L'APPAREIL, COMME INDIQUÉ.

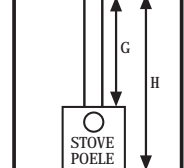
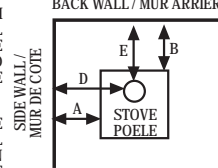

CAUTION: HOT WHILE IN OPERATION. DO NOT TOUCH. KEEP CHILDREN AND CLOTHING AWAY. CONTACT MAY CAUSE SKIN BURNS. SEE NAMEPLATE AND INSTRUCTIONS. KEEP FURNISHINGS AND OTHER COMBUSTIBLE MATERIALS A CONSIDERABLE DISTANCE AWAY FROM THE APPLIANCE. DO NOT OVERFIRE - IF HEATER OR CHIMNEY GLOWS, YOU ARE OVERFIRING.



ATTENTION: CHAUD LORDS DU FONCTIONNEMENT. NE PAS TOUCHER, LE CONTACT PEU CAUSER DES BRULURES A LA PEAU. GARDEZ LES ENFANTS, LES VETEMENTS, LES MEUBLES, ET TOUS LES MATÉRIEAUX COMBUSTIBLES LOIN DE L'ESPACE DESIGNÉ DE L'APPAREIL. LIRE ATTENTIVEMENT LES ETIQUETTES ET LES INSTRUCTIONS. NE PAS SURCHAUFFER. SI L'APPAREIL OU LE TUYAU DE CHEMINÉE ROUGISSENT, VOUS SURCHAUFFEZ.

Manufactured By: / Fabriqué par: BOSCA CHILE S.A. Americo Vespucio Norte 2077 - Huechuraba - Santiago - Chile MADE IN CHILE / FABRIQUÉ AU CHILI

U.S. ENVIRONMENTAL PROTECTION AGENCY
 Certified to comply with July 1990 particulate emission standards:
 Certifié conforme aux normes EPA de juillet 1990 pour les émissions de particules solides

2006	2007	2008	Jan.	Feb.	Mar.	Apr.	May	June	July	Aug.	Sep.	Oct.	Nov.	Dec.
<input type="checkbox"/>	<input type="checkbox"/>	<input type="checkbox"/>	<input type="checkbox"/>	<input type="checkbox"/>	<input type="checkbox"/>	<input type="checkbox"/>	<input type="checkbox"/>	<input type="checkbox"/>	<input type="checkbox"/>	<input type="checkbox"/>	<input type="checkbox"/>	<input type="checkbox"/>	<input type="checkbox"/>	<input type="checkbox"/>

LIFETIME LIMITED WARRANTY**Statement of Policy:**

BOSCA warrants its products from component failure and defects in material or workmanship per the terms of the warranty supplied with the product. All dealers and distributors shall honor BOSCA's warranties, regardless of whether they sold and installed the product or not.

Installation and startup procedures are considered to be normal required activities not associated with warranty service. Issues such as air shutter adjustments or venting should be included in startup. Such procedures are not covered by warranty.

Warranty Period:

The warranty period for consumers begins at date of occupancy (new construction) or date of installation (remodel).

Limited Lifetime Warranty:

BOSCA's limited lifetime warranty guarantees that the following components will work as designed for the first 5 years on all Wood Stoves to the original purchaser. This warranty covers: firebox, firebox panels, panels and door assembly. Certain restrictions and exclusion may apply.

One Year Warranty:

Under this warranty, BOSCA covers all exterior surface finishes against defects in material and workmanship, for part repair or replacements and limited for the first year to the original purchaser. Certain restriction and exclusions may apply.

CONDITIONS

This warranty is non-transferable and is made to the original retail purchaser only provided that the purchase was made through an authorized dealer of BOSCA. It must be installed and operated at all times in accordance with the Installation and Operating Instructions furnished with the product, as well as any applicable local and national codes. Any alteration, willful abuse, accident, or misuse of the product shall nullify this warranty. This limited Lifetime Warranty does not extend to or included surface finish on the appliance, door gasketing, glass gasketing, glass, firebricks. It does not cover installation or operational-related problems such as overfiring, use of corrosive driftwood, downdrafts or spillage caused by environmental conditions, nearby trees, buildings, hilltops, mountains, inadequate venting or ventilation, excessive offsets, or negative air pressures caused by mechanical systems such as furnaces, fans, clothes dryers, etc. Any installation, construction, transportation, or other related costs or expenses arising from defective part(s), repair, replacement, etc., will not be covered by this warranty, nor will BOSCA assume responsibility for them. Further, BOSCA will not be responsible for any incidental, indirect, or consequential damages, except as results in damage to the interior or exterior of the building in which this appliance is installed. This limited Lifetime Warranty does not apply to the venting components, hearth components or other accessories used in conjunction with the installation of this product not manufactured by BOSCA.

This warranty is void if the stove has been over fired or operated in atmospheres contaminated by chlorine, fluorine, or other damaging chemicals, the stove is subjected to prolonged periods of dampness or condensation, or there is any damage to the stove or other components due to water or weather damage which is the result of, but not limited to, improper chimney or venting installation. BOSCA may, at its discretion, fully discharge all obligations with respect to this warranty by either repairing or replacing the unit, or refunding the wholesale price of the defective part(s).

The warranty extended by BOSCA described above covers only the stoves appliances sold in the United States and Canada, and will be considered null or void if the Serial Label is removed or altered.

The Dealer is not authorized to alter this warranty.

Warranty limitations may not apply in your area. This warranty gives you specific legal rights. You may also have other rights which vary from state to state.

All other stove warranties, expressed or implied are excluded to the extent possible by law. In addition, consumers also may have other rights under relevant State and Commonwealth Laws.

LIFETIME LIMITED WARRANTY

IMPORTANT INFORMATION

Model: -----
Style: -----
Serial Number: -----
Purchase Date: -----
Purchased From: -----

BOSCA CHILE S.A.
Av. Américo Vespucio 2077
Huechuraba
Santiago - Chile
Telephone : (56) 2 3288500
Fax: (56) 2 624 1891

Made in Chile

www.boscastoves.com